



www.santos.fr



BAR BLENDER # 33
For cocktails, smoothies, milkshakes...



Internationally patented models





FOR ALL KINDS OF COCKTAILS AND DRINKS

Efficient small bar blender to make quickly any kind of preparation with crushed ice: cocktails, smoothies, frozen drinks, fruits juices, milkshakes. ...

Easy to use, this is the ideal appliance for bars, hotels, restaurants and health food stores.

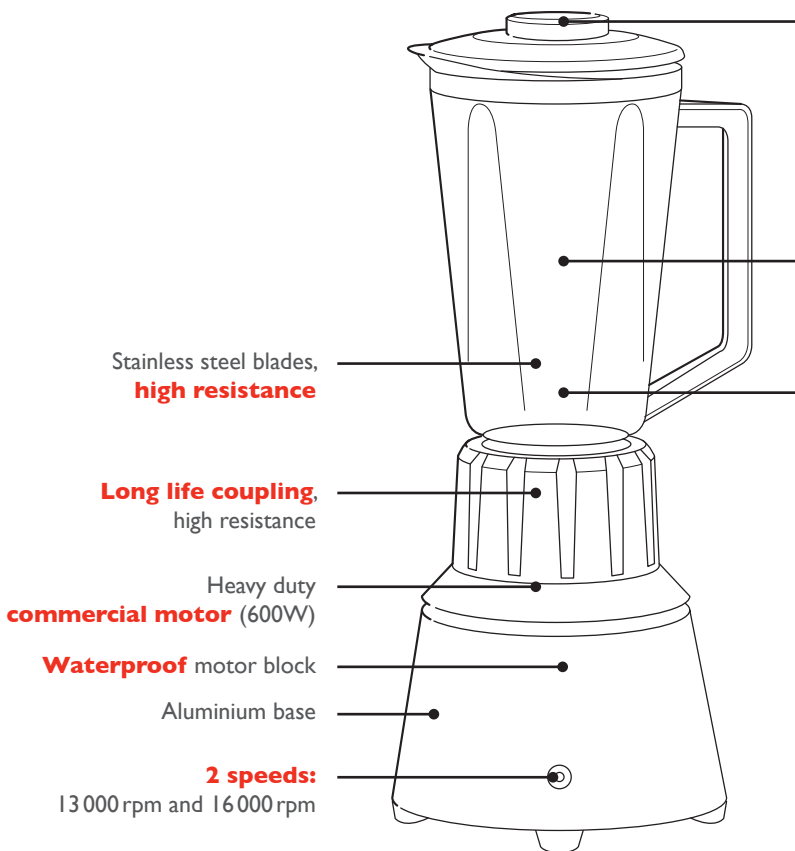

Cover with filler-cap to add ingredients while blending

Graduated container 1,25L (44oz)

Reinforced aluminium cutting assembly



#33 Evolution



33 GE
Grey

33 E
Green

33 CE
Chromed



The bar blender #33 Evolution is now equipped with a bowl detection: the motor stops when you remove the bowl from the base. This bowl detection will help preserving the coupling system.

A WIDE RANGE OF BLENDERS



CHOOSE
THE BLENDER SUITABLE
FOR YOU...

Thanks to the wide range of Santos blenders,
you can make all sorts of drinks,
cocktails, soups...

BAR BLENDER #33



RELIABLE AND EASY TO USE

www.santos.fr

Reliable bar blender

- Powerful commercial motor (600 W)
- Strong stainless steel blades, with reinforced aluminium cutting assembly
- Aluminium base

Easy to use and maintain

- Quick coupling of container on motor base
- Removable parts for easy cleaning: container, cover, container base screw and gasket, cutting assembly
- Filler-cap to add ingredients while blending
- 2 speeds for an easy control of your preparation



33 E

33 GE

33 CE

Choose your color :
green, grey or chromed

TECHNICAL SPECIFICATIONS



Motor

Single phase: 110-120V – 50/60 Hz – 600 W CE
220-240V – 50/60 Hz – 600 W CE

2 speeds: 13000 rpm and 16000 rpm



Weight

Net: 2.9 Kg (6.4 lbs)

Shipping: 3.5 Kg (7.7 lbs)

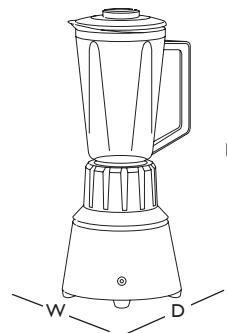

APPLIANCE

W: 180 mm (7")
D: 180 mm (7")
H: 420 mm (17")

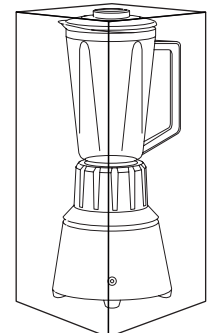

SHIPPING BOX

W: 210 mm (8")
D: 230 mm (9")
H: 475 mm (19")

SAFETY, STANDARDS, HYGIENE

In accordance with the following regulations

Machinery directive 2006/42/EC
Electromagnetic compatibility 2004/108/EC
"Low voltage" Directive 2006/95/EC
RoHS directive 2002/95/EC
Regulation 1935/2004/EC (contact with food)

Harmonized European standards:

- EN ISO 12100 - 1 and 2: 2004
- EN 60204-1: 2006
- EN 12852 + A1 : 2010 Food processors and blenders safety and hygiene requirements
- CE (Europe)

Thermal safety

Motor protected by internal thermal detector

Electrical safety

All mechanical parts are ground connected.
Appliances are 100% tested after assembly.

Hygiene

All removable parts can be put in a dishwasher or easily cleaned with hot soapy water.

2-YEAR WARRANTY

BAR BLENDER #33



www.santos.fr

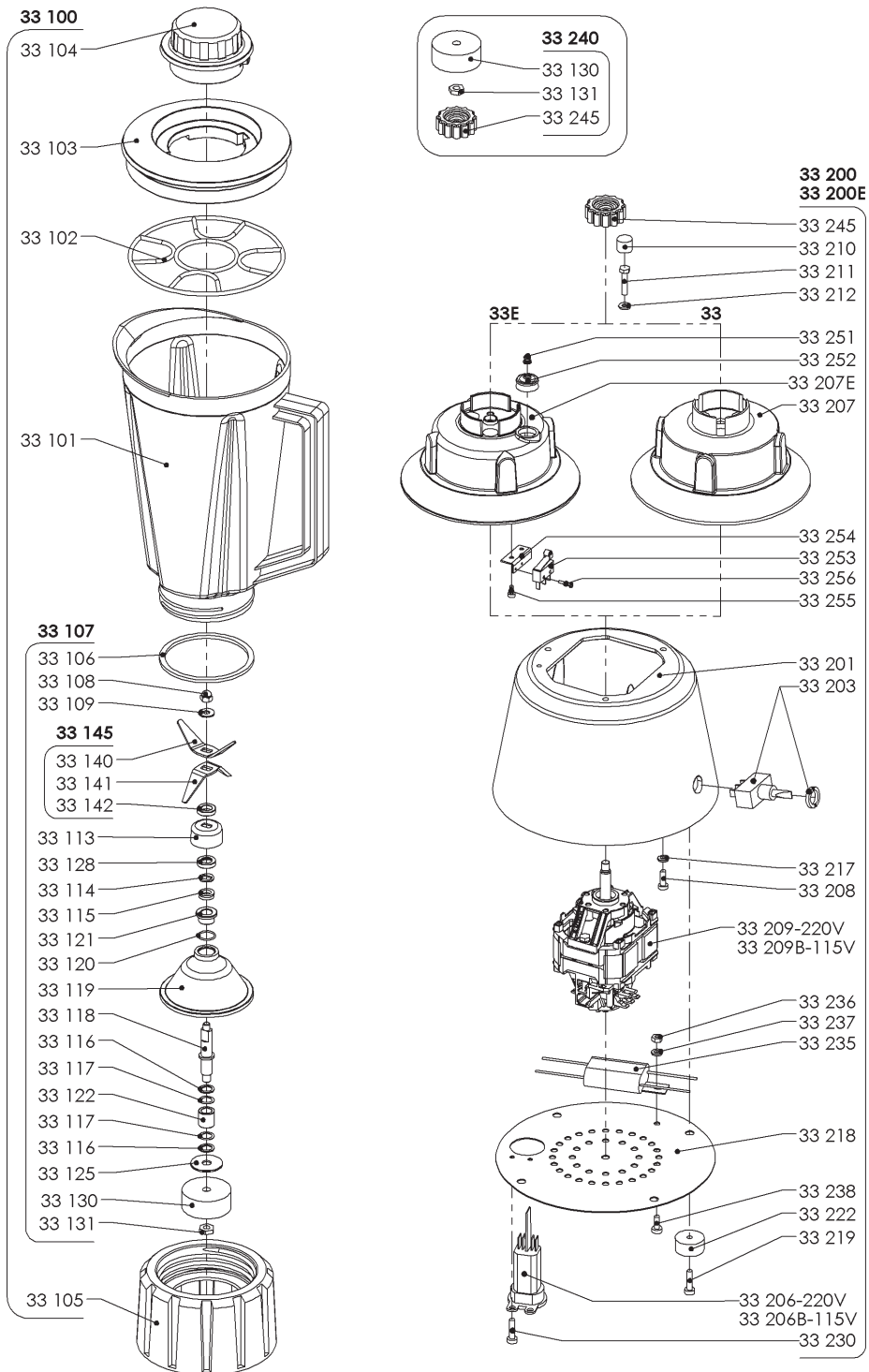

SANTOS

140-150 Avenue Roger Salengro – 69120 VAULX-EN-VELIN – LYON – FRANCE – TEL. +33 472 37 35 29 – FAX. +33 478 26 58 21

Website: www.santos.fr – E-mail: santos@santos.fr